



IPB CONTOUR CONSOLE

(INTEGRATED PRINTEK BROTHER)

FORD PI UTILITY 2020+

Installation Instructions

425-6508



Note: Requires OEM cover plate.

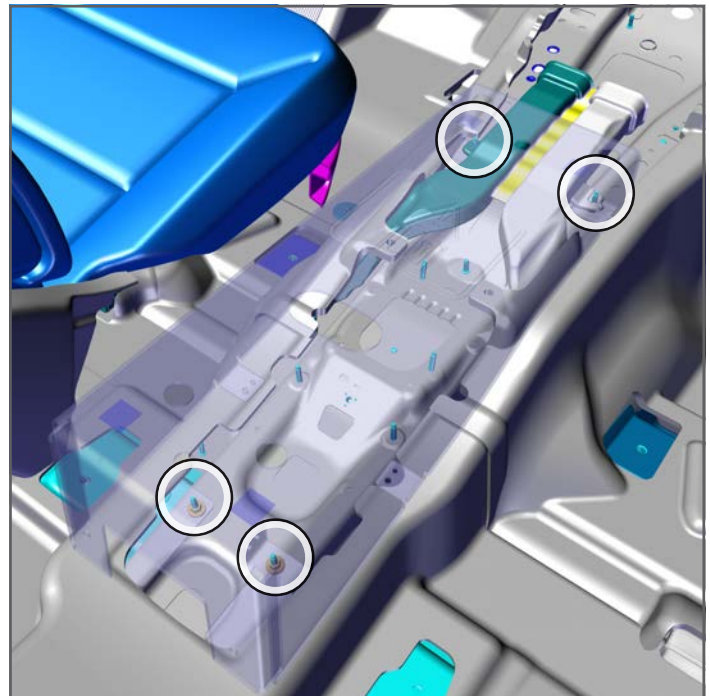
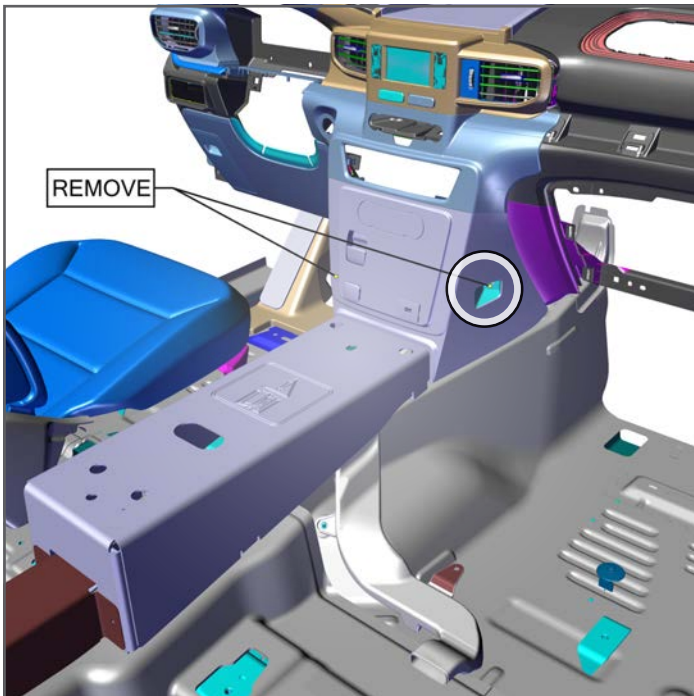

1. Unscrew lower OEM trim. Keep hardware for IPB Contour Console.
2. Remove lower OEM trim by disconnecting the 12v Power, USB, Parking Brake and Rear Air Control for relocation into IPB Contour Console.
3. Remove the factory OEM front and rear 10 mm nuts holding the OEM Cover Plate in place.
4. Temporarily remove Cover Plate from vehicle.

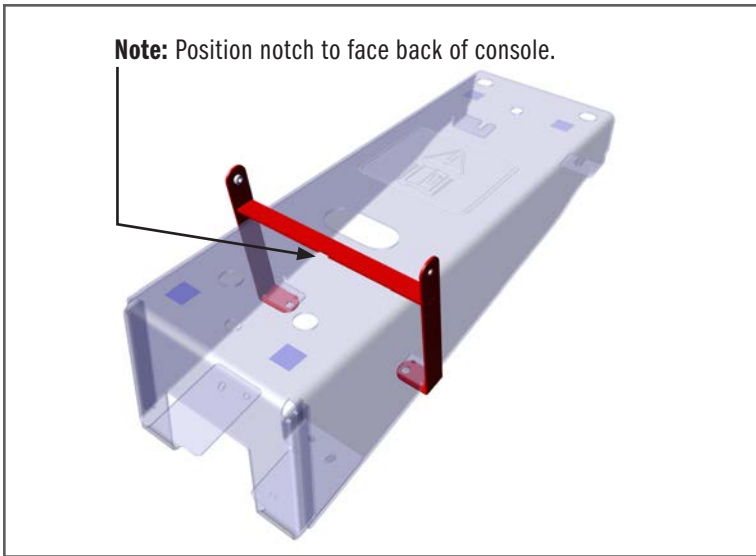

5. Attach the Rear Mounting Bracket with notch facing rear of vehicle using provided hardware.

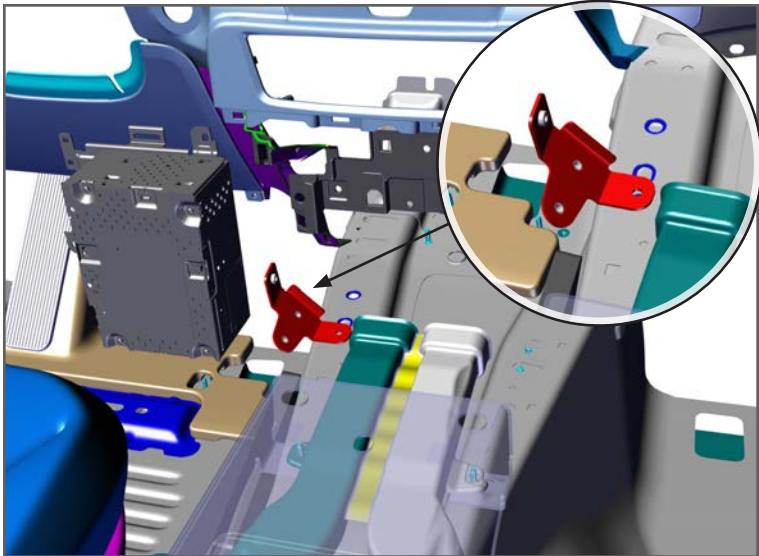

6. Remove D/S front OEM 10 mm screw and attach D/S Front Bracket.

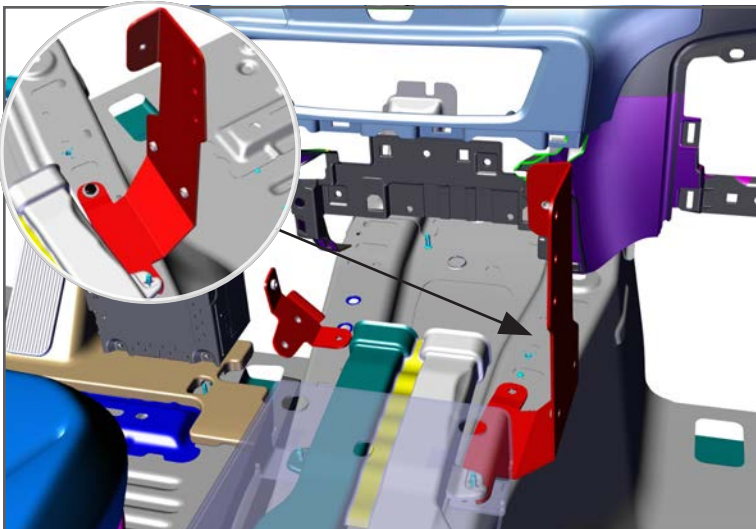

7. Attach the P/S Front Bracket by first detaching the OEM radio and moving it to the left. Secure the D/S Front Bracket rear mount hole to the stud, under the air ducts mounting tab with previously removed 10 mm nut. Line front mounting hole up w/OEM hole, mark and drill OEM hole out to 25/64th to allow installation of AVK fastener (see added instructions). Once AVK Fastener has been installed, position bracket and secure front hole with provided bolt.

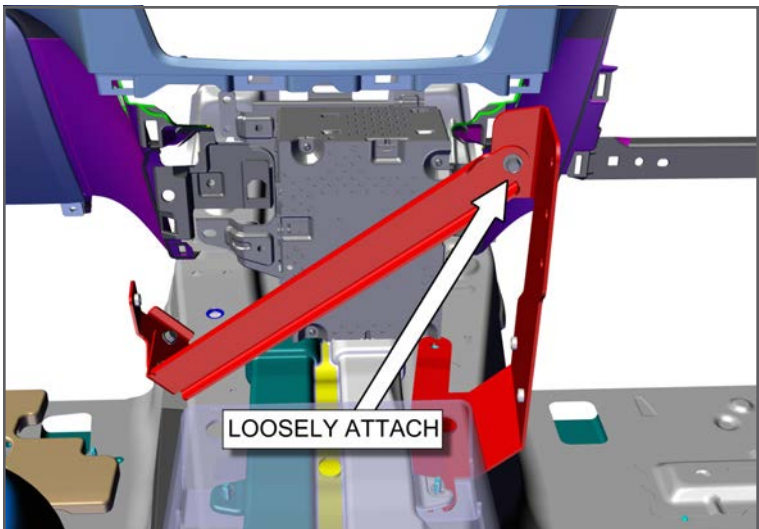

8. Relace OEM Radio and loosely attach Cross Brace for added support.

9. Reinstall Cover Plate. Fully tighten 10 mm nuts.

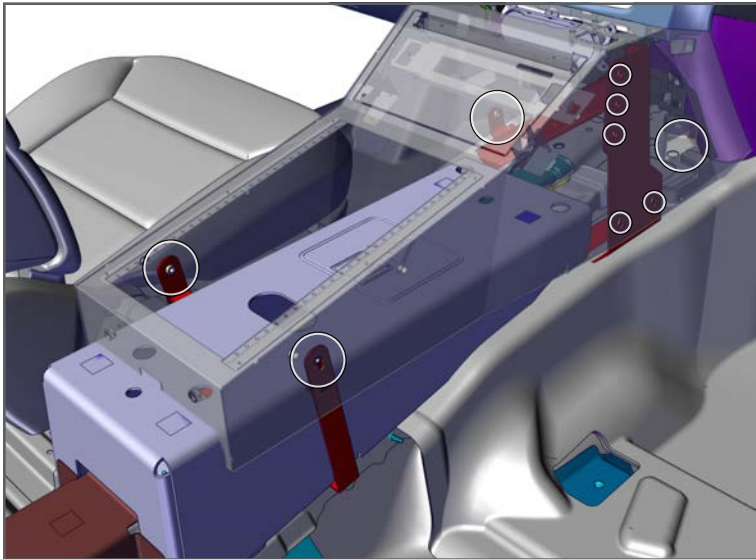

10. Position the IPB Contour Console on top of the OEM Cover Plate.

11. With provided hardware secure the Console to the previously attached Front and Rear Mounting Brackets and to the OEM Dash Structure with OEM screws. Fully secure Cross Brace and tighten all remaining hardware.

(4 points for IPB Contour Console with OEM hardware;
9 points if using provided hardware.)

**If you have questions or need further assistance
please call Technical Support: 1.877.455.6886**



AVK FASTENER INSTALLATION INSTRUCTIONS



AVK Installation video can be viewed at:
<http://jottopublicsafety.gojotto.com/additional-categories/downloads.html>



1. Drill out existing hole to 1/2" or drill new hole per installation instructions.



2. Place 5/16-18 x 1.5" long bolt through the 3/8" flange nut and hand thread bolt into the AVK Fastener.



3. Place into 1/2" drilled hole.

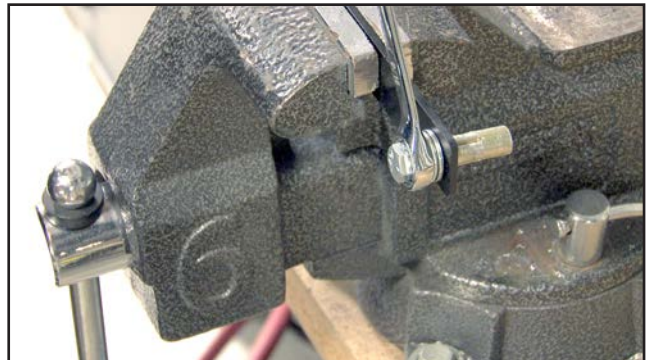

4. Use 9/16" box end wrench to secure the flange nut.



5. Apply pressure on the flange nut, pressing AVK Fastener into hole.

6. Using an air wrench, tighten the 5/16-18 x 1.5" bolt.



7. This will allow the AVK Fastener to secure onto the backside of the metal.

8. Remove 5/16-18 x 1.5" bolt.

